

CONCRETE CANVAS FRAME OPERATING AND SAFETY INSTRUCTIONS

WARNING!

- Any alterations to this hire equipment may prove dangerous to the operator and will be in breach of the Equipment Hire Agreement. Service must only be performed by an authorised Geofabrics service organisation or representative.
- Please contact Geofabrics (0800 60 60 20) for return of this equipment or servicing if it is found to be faulty.
- All hire related documentation, operating and safety instructions are available on our website (www.geofabrics.co.nz).

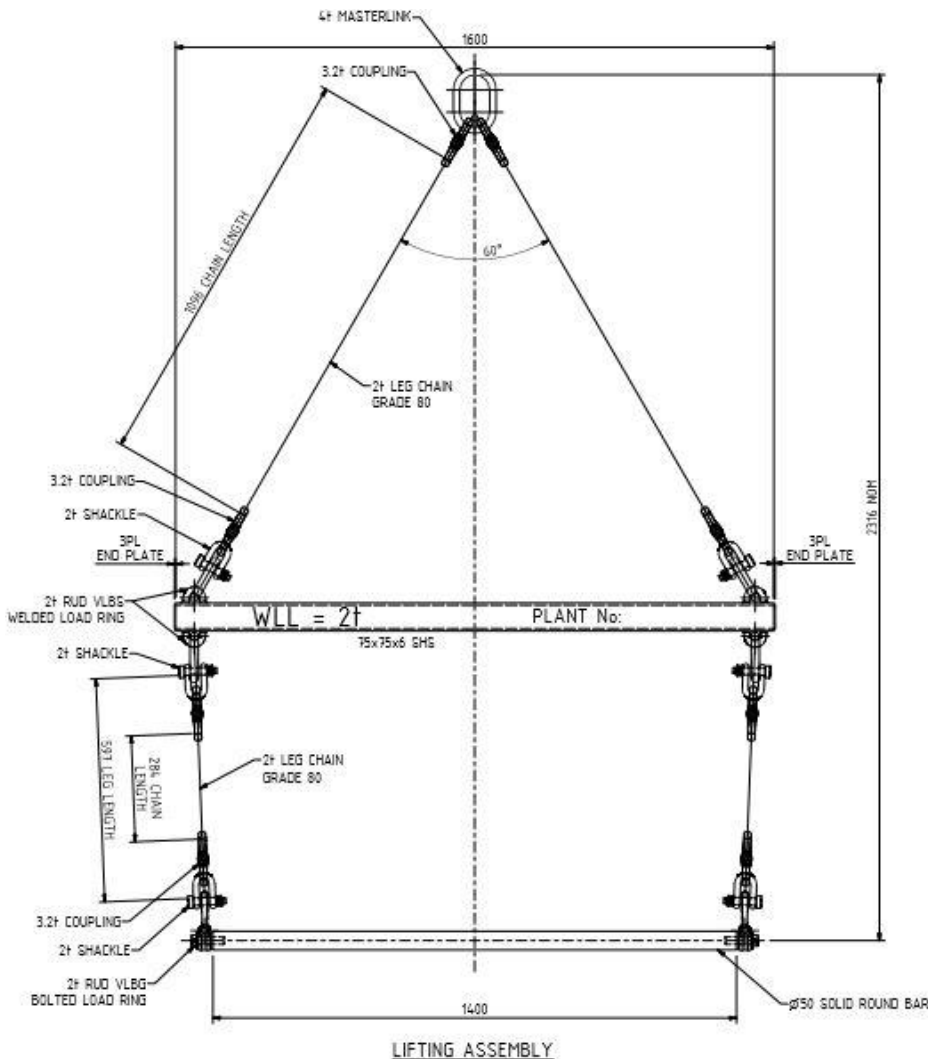

Figure 1

The Concrete Canvas frame (**Fig 1**) is designed to be used as an attachment to suitable earthmoving equipment for the installation of Concrete Canvas' products on containment areas, slopes, channels and other suitable construction areas.

PRE-OPERATIONAL CONSIDERATIONS

- Before operating the Concrete Canvas frame, it is important that you read and understand the maintenance and safety precautions outlined below and in the Equipment Hire Agreement document (Use and Maintenance).
- Contact Geofabrics (0800 60 60 20) if you do not understand any of the instructions in this document.
- To operate the Concrete Canvas frame, operators must be in good physical and mental condition. Do not operate if on medication or under the influence of alcohol or drugs. Seek medical advice if unsure.
- As the installation of Concrete Canvas products is considered a construction activity, the contractor using the hire equipment must prepare and implement a site safety plan that incorporates the safe work methods for high risk work involving the Concrete Canvas frame.

SAFETY PRECAUTIONS AND WORKING TECHNIQUES

- Because the Concrete Canvas frame is suspended/slung from excavators, cranes and other pieces of mobile plant, site specific safety precautions must be observed to reduce the risk of people being hit/struck by the mobile apparatus.
- Steel capped safety boots must always be worn while operating or working near the Concrete Canvas frame. Keep all body parts clear of the equipment at all times when the equipment is in use.
- Always use appropriate personal protective equipment such as riggers gloves, high visibility clothing (shirt or tabard), hard hats and safety eye wear with side protectors.
- Do not use the Concrete Canvas frame for any application other than its intended purpose.
- Do not abuse the Concrete Canvas frame in any way which may result in personal injury and/or damage to the equipment.
- Check the condition of the Concrete Canvas frame (including D shackles and chains) before each use for any damage. If the behaviour of the Concrete Canvas frame changes, check it immediately and return it to Geofabrics for service if necessary.
- Never modify the equipment in any way.
- Do not allow workers to walk on fabric within 10 metres of the roll and equipment in consideration of the possibility of the roll detaching from the equipment or mobile plant.
- When deploying Concrete Canvas down slopes, ensure that the excavator or controlling plant is positioned to minimise the possibility of rolls dislodging and rolling towards people who would otherwise be positioned in an exposed area below the roll.

WARNING! When deploying geosynthetic rolls from a lifting frame, the roll end should be first fixed in place and the lifting frame then moved in a slow and even manner to ensure that no overspinning of the roll occurs on the central steel bar (as picture below). Rolls should be deployed from just above ground level so they can be lowered down quickly to minimise over spooling.

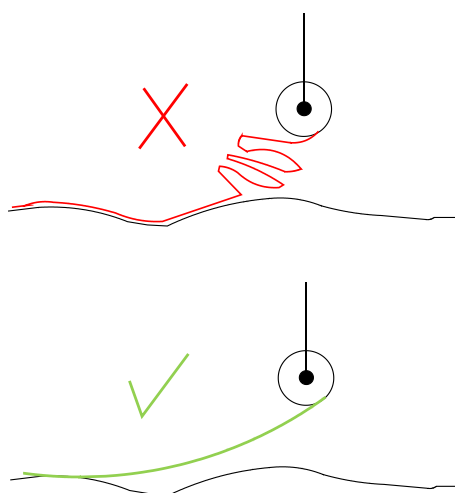

SITE CONDITIONS

- The Concrete Canvas frame is designed for the application of Concrete Canvas products to suitable construction site areas. The Concrete Canvas frame should not be operated in conditions which could endanger the operator or other site personnel.

CONCRETE CANVAS FRAME COMPONENTS

- To ensure no parts are lost, all components should be stored and transported as a set, in such a way as not to cause damage to the equipment.

USING THE CONCRETE CANVAS FRAME

Please refer to the following guidelines available for Geofabrics appropriate for your installation:

- CC Installation Guide – Ditch Lining
- CC Installation Guide – Slope Protection
- CC Installation Guide – Bund Lining
- CC Installation Guide – Remediation

GEOFABRICS NEW ZEALAND LTD.

19 Druces Road, Wiri. P.O. BOX 12536, Penrose, Auckland, New Zealand
Tel. (+64) 9 6346495, FREEPHONE 0800 60 60 20
E-mail: sales@geofabrics.co.nz - Web site: www.geofabrics.co.nz
Quality System AS/NZS ISO 9001:2015

The information contained herein is general in nature. In particular the content herein does not take account of specific conditions that may be present at your site. Site conditions may alter the performance and longevity of the product. Actual dimensions and performance may vary and in all cases we recommend that advice be obtained from a suitably qualified consulting engineer or industry specialist before proceeding with installation. © Copyright held by Geofabrics NZ Ltd. All rights are reserved and no part of this publication may be copied without prior permission.