

Anderton Concrete Products Ltd

Units 1 and 2
Cosgrove Business Park
Soot Hill
Anderton
Northwich
Cheshire CW9 6AA

Tel: 01606 535300 Fax: 01606 75905
e-mail: civils@andertonconcrete.co.uk
website: www.andertonconcrete.co.uk



HAPAS Certificate
14/H217
Product Sheet 1

ANDERTON CONCRETE RETAINING WALL SYSTEMS

KEYSTONE RETAINING WALL SYSTEM FOR REINFORCED SOIL RETAINING WALLS AND BRIDGE ABUTMENTS

This HAPAS Certificate Product Sheet⁽¹⁾ is issued by the British Board of Agrément (BBA), supported by the Highways Agency (HA) (acting on behalf of the Overseeing Organisations of the Department for Transport; Transport Scotland; the Welsh Assembly Government and the Department for Regional Development, Northern Ireland), the Association of Directors of Environment, Economy, Planning and Transport (ADEPT), the Local Government Technical Advisers' Group and industry bodies. HAPAS Certificate Product Sheets are normally each subject to a review every three years.
(1) Hereinafter referred to as 'Certificate'.

This Certificate relates to the Keystone⁽¹⁾ Retaining Wall System for Reinforced Soil Retaining Walls and Bridge Abutments, comprising modular concrete block facing units, Tensar RE500 geogrids, high density polyethylene (HDPE) polymeric connector strips, glass fibre reinforced (GRP) dowels and compacted fill material. The system is for use in reinforced soil retaining walls and bridge abutments up to a maximum height of 10 metres.

(1) Keystone is a registered trade mark.

CERTIFICATION INCLUDES:

- factors relating to compliance with HAPAS requirements
- factors relating to compliance with Regulations where applicable
- independently verified technical specification
- assessment criteria and technical investigations
- design considerations
- installation guidance
- regular surveillance of production
- formal three-yearly review.



KEY FACTORS ASSESSED

Mechanical properties — the method of connection between the geogrids and concrete block facing units has been assessed and long-term connection strength values determined for various wall heights and concrete block/geogrid combinations (see Section 7). The interface shear capacity between adjacent concrete block facing units in between layers of geogrid reinforcement has been assessed and is satisfactory (see section 6).

Performance of geogrids — the short- and long-term tensile strength of the geogrids, resistance to installation damage, weathering and environmental effects and soil/geogrid interaction have been assessed⁽¹⁾.

Durability — when designed and installed in accordance with the provisions of this Certificate, the system will have adequate durability for its intended use as a retaining wall or bridge abutment (see section 9).

(1) Data and reduction factors for use in design are given in Agrément Certificate 13/H201 Product Sheet 1.

The BBA has awarded this Certificate to the company named above for the system described herein. This system has been assessed by the BBA as being fit for its intended use provided it is installed, used and maintained as set out in this Certificate.

On behalf of the British Board of Agrément

Date of First issue: 26 June 2014

Brian Chamberlain
Head of Approvals — Engineering

Claire Curtis-Thomas
Chief Executive

The BBA is a UKAS accredited certification body — Number 113. The schedule of the current scope of accreditation for product certification is available in pdf format via the UKAS link on the BBA website at www.bbacerts.co.uk

Readers are advised to check the validity and latest issue number of this Agrément Certificate by either referring to the BBA website or contacting the BBA direct.

British Board of Agrément
Bucknalls Lane
Watford
Herts WD25 9BA

©2014

tel: 01923 665300
fax: 01923 665301
e-mail: mail@bba.star.co.uk
website: www.bbacerts.co.uk

Requirements

In the opinion of the BBA, the Keystone Retaining Wall System for Reinforced Soil Retaining Walls and Bridge Abutments, when designed and installed in accordance with the provisions of this Certificate, will meet the requirements of the Highways Agency and local Highway Authorities for the design and construction of reinforced soil retaining walls and bridge abutments.

Regulations

Construction (Design and Management) Regulations 2007

Construction (Design and Management) Regulations (Northern Ireland) 2007

Information in this Certificate may assist the client, CDM co-ordinator, designer and contractors to address their obligations under these Regulations.

See sections: 1 Description (1.2) 3 Delivery and site handling (3.1) and the Installation part of this Certificate.

Additional Information

CE marking

The Certificate holder has taken the responsibility of CE marking the modular concrete block facing units in accordance with harmonised European Standard BS EN 771-3 : 2011. The supplier of the geogrids has taken the responsibility of CE marking the geogrids in accordance with harmonised European Standard BS EN 13251 : 2001. An asterisk (*) appearing in this Certificate indicates that data shown is given in the manufacturers' Declarations of Performance.

Technical Specification

1 Description

1.1 The Keystone Retaining Wall System for Reinforced Soil Retaining Walls and Bridge Abutments comprises:

- Keystone COMPAC modular concrete block facing units
- Tensar RE520, RE540, RE560 and RE580 geogrids⁽¹⁾
- polymeric connectors
- pultruded GRP dowels
- selected granular material to fill to all voids, in, around and behind the facing units
- compacted fill.

(1) Covered under Agrément Certificate 13/H201 Product Sheet 1.

Concrete block facing units

1.2 The modular concrete block facing units covered by this Certificate are described in Table 1 and shown in Figure 1. All units are manufactured to the same specification. Non-structural coping units are also available but are outside the scope of this Certificate.

Figure 1 Keystone Compac modular concrete block facing units



Table 1 Keystone Compac modular concrete block facing units

Block type	Split faced	Rock faced	Smooth faced	Pitched face
Description/use	Facing unit	Facing unit	Facing unit	Facing unit
Face finish	split	split	smooth	split
Dimensions (L x W x H) mm (*)	455 x 300 x 200	455 x 300 x 200	455 x 300 x 200	455 x 300 x 200
Nominal weight (kg)	40	39.5	40	39.5

An asterisk (*) indicates that data shown is given in the manufacturer's Declaration of Performance under CE marking.

1.3 The blocks are manufactured from concrete with a minimum 28 day cube strength of 40 N·mm⁻² and satisfy the Highways Agency's requirements for durability of class XF2 exposure to BS 8500-1 : 2006.

1.4 The blocks conform to BS EN 771-3 : 2011. The essential characteristics given in Table 2 have been declared by the manufacturer.

Table 2 Essential characteristics in accordance with BS EN 771-3

Characteristic	Test method	Certificate holder's declared value (*)
Dimensions (mm)	BS EN 771-3	As shown in Table 1
Dimensional tolerances		Category D2
Configuration		Group 1 to EN 1996-1-1
Reaction to fire		Euroclass A1
Compressive strength (N·mm ⁻²)	BS EN 772-1	40
Gross dry density (kg·m ⁻³)	BS EN 772-13	2100

An asterisk (*) indicates that data shown is given in the manufacturer's Declaration of Performance under CE marking.

1.5 All pigments used for the colouration of the concrete blocks comply with BS EN 12878 : 2005.

Geogrids

1.6 The following grades of Tensar RE500 geogrids⁽¹⁾ have been assessed by the BBA for use with the Keystone Retaining Wall System:

Tensar RE520

Tensar RE540

Tensar RE560

Tensar RE580.

(1) Full product details are given in Agrément Certificate 13/H201 Product Sheet 1.

Polymeric connectors

1.7 The polymeric connectors are manufactured from high density polyethylene to one specification to the profile shown in Figure 2.

Figure 2 Polymeric connectors

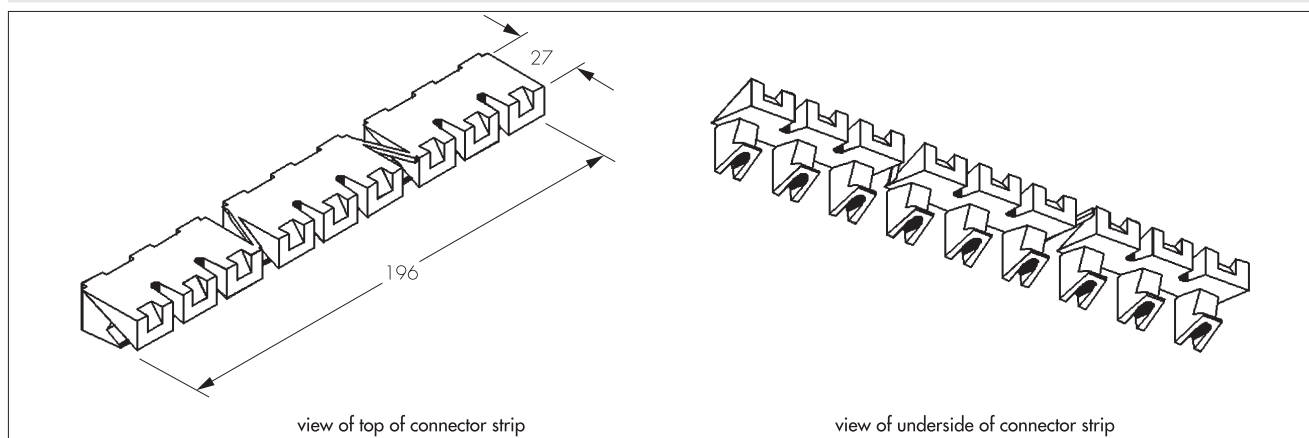

Pultruded GRP dowels

1.8 The dowels are 133 mm in length with a diameter of 12.7 mm, yellow or white in colour and manufactured from pultruded glass reinforced plastic to one specification.

Fill material

1.9 Fill materials must comply with the requirements set out in BS 8006-1 : 2010 and the MCHW, Volume 1.

2 Manufacture

2.1 The concrete block facing units are manufactured to an agreed specification by the Certificate holder. The blocks are moulded on block machines and compacted using mechanical vibratory compaction. Blocks with split face finishes are moulded in pairs and split after drying. Smooth finish blocks are moulded in individual moulds.

2.2 The geogrids are manufactured by Tensar International Ltd. Further details are given in Agrément Certificate 13/H201 Product Sheet 1.

2.3 The polymeric connectors are injection moulded from high density polyethylene to one agreed specification by an approved Manufacturer.

2.4 The GRP dowels are manufactured by pultrusion to achieve the required short – and long term performance by an approved Manufacturer.

2.5 As part of the assessment and ongoing surveillance of the quality of the system components, the BBA has:

- agreed with the Certificate holder and respective manufacturers the quality control procedures and product testing to be undertaken
- assessed and agreed the quality control operated over batches of incoming materials
- monitored the production process and verified that it is in accordance with the documented process
- evaluated the process for management of nonconformities
- checked that equipment has been properly tested and calibrated
- undertaken to carry out the above measures on a regular basis through a surveillance process, to verify that the specifications and quality control operated by the manufacturer are being maintained.

2.6 The manufacturer's management system for the geogrids has been assessed and registered as meeting the requirements of BS EN ISO 9001 : 2008 by BSI (Certificate No. FM 559191).

3 Delivery and site handling

Facing units

3.1 The facing units are delivered to site shrink-wrapped on pallets. They carry a manufacturer's label or marking identifying the product type and batch code. Pallets should not be stacked more than two high.

3.2 To prevent damage, care should be taken in transit and handling. During prolonged periods of storage on site the units should remain covered on pallets.

Geogrids

3.3 The geogrids are delivered and should be handled and stored as detailed in Agrément Certificate 13/H201 Product Sheet 1.

Polymeric connectors

3.4 The polymeric connectors are delivered to site, packaged in multiples of 250 units. The packages are labelled identifying the manufacturer, product type and batch code. The connectors should remain in their packaging until ready for use, since any damage or dirt accumulation will compromise the structural integrity of the connection.

Pultruded GRP dowels

3.5 The GRP dowels are delivered to site in boxes. Care should be taken in storage, transit and handling on site.

Assessment and Technical Investigations

The following is a summary of the assessment and technical investigations carried out on the Keystone Retaining Wall System.

Design Considerations

4 General

4.1 When designed and installed in accordance with this Certificate, the Keystone Retaining Wall System is satisfactory for the construction of reinforced soil retaining walls and bridge abutments up to a maximum height of 10 metres. Walls above this height require special consideration and are outside this scope of the Certificate.

4.2 Structural stability of the wall system is achieved through:

- interface shear capacity between adjacent rows of blocks
- the connection strength between the blocks and geogrid layers at each layer of geogrid
- the tensile strength of the geogrids, and
- the embedment and resistance to sliding and pull out of the geogrids from the fill material.

4.3 The connection between the geogrids and concrete block facing units is formed using the polymeric connector strip (see Figure 3).

4.4 To prevent interface shear, all blocks must be interconnected with the glassfibre dowels, whether or not a reinforcing layer is to be used.

4.5 Prior to the commencement of work, the designer must satisfy the design approval and certification procedures of the relevant Highway Authority.

4.6 The BBA has not assessed the structures for supporting parapet loading caused by vehicle collision at the top of the facing units.

4.7 Reinforced soil structures constructed using the Keystone Retaining Wall System should be protected with suitable barriers, to protect the structure against potential damage from vehicle impact and vehicle fires.

Figure 3 Method of connecting geogrid to concrete block facing unit

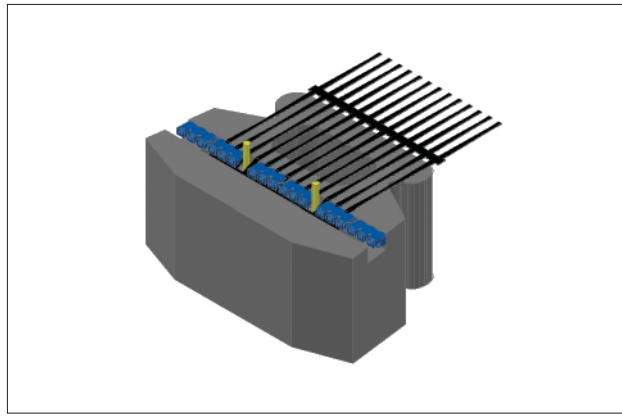

4.8 In addition to those factors covered in section 6 of this Certificate, attention must also be paid in design to:

- site preparation
- fill material properties
- the specification for placing and compaction of the fill material
- drainage behind the wall
- protection of the geogrid against damage during installation.

4.9 It is considered that with correct design and workmanship and by following the recommendations of this Certificate, normally accepted tolerances of line and level for the construction of retaining walls as defined in BS 8006-1 : 2010, Table 18, can be achieved. However, where the alignment of the vertical face is critical, consideration may be given to providing a brickwork skin, or similar, to the facing units (outside the scope of this Certificate).

4.10 Particular attention should be paid to changes in direction of walls where overlapping of the geogrids may occur. BS 8006-1 : 2010 also gives guidance on typical layout plans for the geogrids (reinforcing elements) in bridge abutments.

5 Practicability of installation

The system is designed to be installed by trained contractors in accordance with the specifications and construction drawings (see the *Installation* part of this Certificate).

6 Design

Design methodology

6.1 Reinforced soil retaining walls and bridge abutments constructed using the Keystone Retaining Wall System must be designed in accordance with BS 8006-1 : 2010 and the Specification for Highway Works.

6.2 In accordance with BS 8006-1 : 2010 Annex B, the required design life for permanent walls and bridge abutments is 120 years.

6.3 To evaluate the overall stability of the wall system, it is necessary to consider:

- the design strength and length of embedment of the geogrid (for the ultimate and serviceability limit state)
- the length of embedment of the geogrid within the fill
- the connection strength between the geogrid and concrete block facing units
- the interface shear capacity of the blocks between layers of geogrid reinforcement.

Design strength of geogrids

6.4 The designer must carry out design checks ensure that the geogrids have adequate long-term tensile strength at each layer of reinforcement, to satisfy ultimate limit state and the post construction creep strain serviceability limit state design criteria defined in BS 8006-1 : 2010. Short- and long term tensile strength values and material reduction factors for use in the design of the geogrids are given in Agrément Certificate 13/H201 Product Sheet 1.

Length of embedment of geogrid

6.5 The designer must carry out checks to ensure that the geogrids have adequate length of embedment within the fill to prevent pull-out. Design coefficients for the assessment of soil geogrid interaction and pull-out are given in Agrément Certificate 13/H201 Product Sheet 1.

Connection strength between the geogrids and concrete block facing units

6.6 The design connection strength between the geogrids and concrete block facing units (T_{Dconn}) should be determined for the ULS and checks should be made to ensure that it is not exceeded by the design load (T_i) at each level i.e. $T_i \leq T_{Dconn}$. Particular care should be taken during the design of bridge abutments to ensure that adequate reinforcement is provided and adequate connection strengths are achieved at the top of the wall and in front of bank seats.

6.7 The design connection strength (T_{Dconn}) is determined using the following formula:

$$T_{Dconn} = T_{conn} / f_m f_n$$

Where:

T_{conn} = the long-term connection strength derived from testing (See section 7)

f_m = the material safety factor for the geogrid (see section 7)

f_n = the partial factor for ramification of failure in accordance with BS 8006-1 : 2010, Table 9.

6.8 The minimum value of load factor used in determining the design load should be 1.5 for all designs using the wall system.

Interface shear capacity between concrete block facing units

6.9 The System has adequate interface shear capacity when designed and installed in accordance with this Certificate.

Specification of fill material

6.10 The designer should specify the relevant properties of the fill material for the reinforced soil structure deemed acceptable for the purposes of the design. Acceptable materials should meet the requirements of BS 8006-1 : 2010 and the MCHW, Volume 1, Series 600.

7 Mechanical properties

Geogrids

7.1 Short- and long-term strength values and reduction factors required for design of the geogrids are given in Agrément Certificate 13/H201 Product Sheet 1. These include:

- Characteristic short-term tensile strengths (T_{char}),
- Long-term creep rupture strengths (T_{CR}),
- Maximum permissible loads to limit post-construction creep strain (T_{CS}),
- Reduction factors for installation damage (RF_{ID}), weathering (RF_{WV}) and environmental degradation (RF_{CH})
- Factors of safety for extrapolation of data (f_s)
- coefficients for the assessment of soil/geogrid interaction and resistance to pull-out.

Connection strength between concrete block facing units block and geogrids

7.2 Long-term connection strength values (T_{conn}) for the Keystone Retaining Wall System, have been derived from short-term tests in line with the National Concrete Masonry Association *Design Manual for Segmental Retaining Walls (Second edition 1977)* and ASTM D6638-07. Connection efficiencies determined from these tests have been applied to the long-term creep rupture strength (T_{CR}) values for the geogrids, to determine the relevant long-term connection strengths (T_{conn}). The results are shown in Table 3 and can be used to determine the design connection strength (T_{Dconn}) as set out in Section 6 of this Certificate.

Geogrid grades	$T_{CR}^{(1)}$ (kN·m ⁻¹)	Block height above geogrid reinforcement (m)	T_{conn} (kN·m ⁻¹)
RE520	27.3	1.0 – 1.8	17.3
		1.9 – 2.7	20.0
		2.8 – 4.5	21.0
		4.6 – 6.0	21.3
		6.1 – 9.1	23.0
RE540	33.4	1.4 – 2.3	27.5
		2.4 – 3.8	28.2
		3.9 – 8.0	26.7
		8.1 – 10.0	24.3
RE560	45.9	1.0 – 3.0	36.9
		3.1 – 6.9	37.9
		7.0 – 8.6	37.0
		8.7 – 10.0	32.2
RE580	71.1	2.0 – 3.9	64.4
		4.0 – 7.7	63.8
		7.8 – 9.5	62.7
		9.6 – 10.0	58.4

(1) For a design life of 120 years and a design temperature of 10°C.

7.3 The following reduction factors and factors of safety (Table 4) should be used to determine the material factor f_m required for calculation of the ultimate limit state design connection strength (T_{Dconn}).

Table 4 Reduction factors for determination of T_{Dconn}

Material factor	Factor for	Reduction Factor ⁽¹⁾
RF_{ID}	Installation damage	1.00 ⁽²⁾
RF_W	Weathering	1.00
RF_{CH}	Chemical/Environmental	pH 2 to 4 $RF_{CH} = 1.05$ pH 4 to 12.5 $RF_{CH} = 1.00$
f_s	Extrapolation of data	1.00

(1) For a design life of 120 years and a design temperature of 10°C and subject to installation conditions and restrictions given in Certificate 13/H201 Product Sheet 1.

(2) A value of $RF_{ID} = 1.0$ can be used for all geogrid grades as installation damage is generally taken into account during the connection strength tests.

8 Maintenance

The exposed faces of the concrete block facing units may require periodic maintenance, to remove dirt build up, mould and moss growth. All other components of the system are confined within the wall and/or fill and do not require maintenance.

9 Durability

9.1 When designed and installed in accordance with this Certificate, the system will have adequate durability for the required 120 year design life of a retaining wall and bridge abutment in conditions encountered in the UK.

9.2 Where the blocks are to be embedded in potentially aggressive soils, the guidance given in BS 8500-1 : 2006 and BRE Special Digest 1 : 2005 should be followed.

10 Reuse and recyclability

The concrete facing units can be crushed and re-used as aggregate. The fill material can also be reused.

Installation

11 General

11.1 Installation of the Keystone Retaining Wall System should also comply with the requirements of BS 8006-1 : 2010 and BS EN 14475 : 2006.

12 Procedure

12.1 The formation level is prepared and a suitable concrete foundation is laid to the correct level for the first course of facing units.

12.2 The first course of facing units should always be laid on a mortar bed, or bedded into the fresh concrete, to achieve the required accuracy in line and level. The units should be set out to achieve a distance of 305 mm from pin to pin on adjacent units, thereby creating 2 mm gap between adjacent units. The facing units should be lifted and located by two men using appropriate lifting equipment.

12.3 The GRP dowels should be securely inserted to over half their length into the appropriate holes in the facing units (see Figure 1). All blocks must be inter-connected with glassfibre dowels, whether or not a geogrid layer is to be inserted.

12.4 Facing units should be laid until the required level of the first layer of geogrid. All voids, in between and immediately behind the facing units are filled with the granular fill material. The drainage zone should extend a minimum of 300 mm behind the facing units. Backfill may then be placed and compacted to the level of the first layer of geogrid.

12.5 Fill is placed to a depth not less than 150 mm before each pass of the compaction plant. The material is placed by mechanical plant but to avoid excessive movement of the wall facing, heavy compaction plant should not be employed within two metres of the facing units. Outside this area, a depth of fill not exceeding 150 mm for each pass should be carried out to suit the compaction plant used (MCHW1, Clause 622.7). Installation and compaction of Tensor RE500 geogrids should be as described in BBA Certificate 13/H201, Product Sheet 1.

12.6 In general, the compacted fill should be level to receive the geogrid and the blocks swept to remove all debris. A suitable length of geogrid should be cut from the roll and any protruding ribs trimmed back to within 10 mm of the transverse bar. The prepared end of the grid is placed over the rebate in the block and the polymeric connectors located around the transverse bar. Each aperture of the geogrid must be covered by a connector.

12.7 The assembly is positioned neatly into the rebate of the facing unit and pushed down firmly. The next course of blocks is placed over the GRP dowels, locating the kidney-shaped recesses over the pins, and pushed towards the front of the structure until it makes full contact with both pins. The use of plastic shims to ensure the blocks are level is recommended.

12.8 Depending upon the design, up to three courses of facing units may be laid before inserting a further layer of geogrid (i.e. 606 mm maximum vertical spacing).

12.9 The geogrid should be lightly tensioned using the tensioning beam supplied, so that the polymeric connectors are up against the rear of the rebate.

12.10 The procedure is repeated until the required level for a coping facing unit is reached.

12.11 Connection of lengths of geogrid (other than at the facing units) is carried out using Tensar Bodkins as described and detailed in BBA Certificate 13/H201, Product Sheet 1.

Technical Investigations

13 Tests

13.1 The manufacturing process for the concrete facing units was examined, including the methods adopted for quality control, and details were obtained of the quality and composition of the materials used.

13.2 An examination was made of test data relating to:

- compressive strength and density of the concrete block facing units
- durability
- performance of the retaining wall system under fire test conditions
- assessment, including product specific testing, of the connection strength between the Tensar RE500 geogrids and facing units using the polymeric connector.

13.3 Visits were made to installations in progress to assess the practicability and ease of construction of the system.

Bibliography

ASTM D6638-07 *Standard Test Method for Determining Connection Strength Between Geosynthetic Reinforcement and Segmental Concrete Units (Modular Concrete Blocks)*

BRE Special Digest 1 : 2005 *Concrete in aggressive ground : Part C Assessing the aggressive chemical environment*

BS 8500-1 : 2006 +A1 : 2012 *Concrete — Complementary British Standard to BS EN 206-1 Method of specifying and guidance for the specifier*

BS 8006-1 : 2010 *Code of practice for strengthened/reinforced soils and other fills*

BS EN 771-3 : 2011 *Specification for masonry units Aggregate concrete masonry units (dense and lightweight aggregates)*

BS EN 772-1:2011 *Methods of test for masonry units. Determination of compressive strength*

BS EN 772-13:2000 *Methods of test for masonry units. Determination of net and gross dry density of masonry units (except for natural stone)*

BS EN 12878 : 2005 *Pigments for the colouring of building materials based on cement and/or lime — Specifications and methods of test*

BS EN 13251 : 2001 *Geotextiles and geotextile-related products — Characteristics required for use in earthworks, foundations and retaining structures*

BS EN 14475 : 2006 *Execution of special geotechnical works — Reinforced fill*

EN 1996-1-1 : 2005 +A1 : 2012 *Eurocode 6 — Design of masonry structures — General rules for reinforced and unreinforced masonry structures*

Manual of Contract Documents for Highway Works, Volume 1 *Specification for Highway Works National Concrete Masonry Association Design Manual for Segmental Retaining Walls (Second edition 1977)*

14 Conditions

14.1 This Certificate:

- relates only to the product/system that is named and described on the front page
- is issued only to the company, firm, organisation or person named on the front page — no other company, firm, organisation or person may hold or claim that this Certificate has been issued to them
- is valid only within the UK
- has to be read, considered and used as a whole document — it may be misleading and will be incomplete to be selective
- is copyright of the BBA
- is subject to English Law.

14.2 Publications, documents, specifications, legislation, regulations, standards and the like referenced in this Certificate are those that were current and/or deemed relevant by the BBA at the date of issue or reissue of this Certificate.

14.3 This Certificate will remain valid for an unlimited period provided that the product/system and its manufacture and/or fabrication, including all related and relevant parts and processes thereof:

- are maintained at or above the levels which have been assessed and found to be satisfactory by the BBA
- continue to be checked as and when deemed appropriate by the BBA under arrangements that it will determine
- are reviewed by the BBA as and when it considers appropriate.

14.4 The BBA has used due skill, care and diligence in preparing this Certificate, but no warranty is provided.

14.5 In issuing this Certificate, the BBA is not responsible and is excluded from any liability to any company, firm, organisation or person, for any matters arising directly or indirectly from:

- the presence or absence of any patent, intellectual property or similar rights subsisting in the product/system or any other product/system
- the right of the Certificate holder to manufacture, supply, install, maintain or market the product/system
- actual installations of the product/system, including their nature, design, methods, performance, workmanship and maintenance
- any works and constructions in which the product/system is installed, including their nature, design, methods, performance, workmanship and maintenance
- any loss or damage, including personal injury, howsoever caused by the product/system, including its manufacture, supply, installation, use, maintenance and removal
- any claims by the manufacturer relating to CE marking.

14.6 Any information relating to the manufacture, supply, installation, use, maintenance and removal of this product/system which is contained or referred to in this Certificate is the minimum required to be met when the product/system is manufactured, supplied, installed, used, maintained and removed. It does not purport in any way to restate the requirements of the Health and Safety at Work etc. Act 1974, or of any other statutory, common law or other duty which may exist at the date of issue or reissue of this Certificate; nor is conformity with such information to be taken as satisfying the requirements of the 1974 Act or of any statutory, common law or other duty of care.